

STANDARD
Bolted (2) Sides

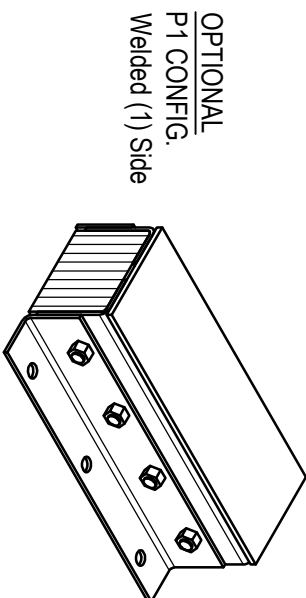

OPTIONAL
P1 CONFIG.
Welded (1) Side

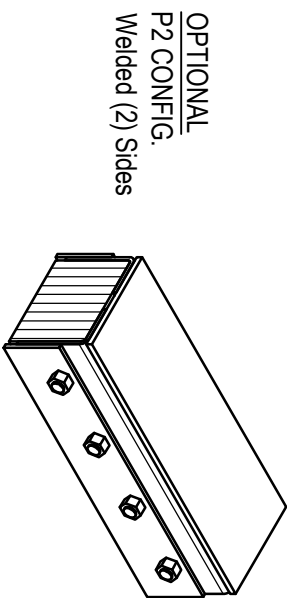

OPTIONAL
P2 CONFIG.
Welded (2) Sides

SPECIFICATIONS:

LAMINATED PADS SHALL BE MADE FROM RECYCLED CONVEYOR BELTING AND TIRE RUBBER CUT TO 3.25" x 10" PUNCHED AND ASSEMBLED THROUGH 3/4" RODS BETWEEN 3" x 5" x 1/4" FORMED STEEL UNDER 1,500LBS OF PRESSURE. FINISH OF EXPOSED METAL SHALL BE PAINTED WITH WATER-BASED.

| DATE | REV. NO. | BY | DESCRIPTION |
|---|-------------------------|----|-------------|
|  | | | |
| STEEL-FACED LAMINATED BUMPER D-2014-5 SF-38 | | | |
| DATE: APR-22-20 | SCALE: 1:10 | | |
| DRAWN: AS | DWG NO: D-2014-5 SF-38 | | |
| APPROVED: ST | PART NO: D-2014-5 SF-38 | | |