

OPENING HEIGHT

54"

3" OVERLAP

OPENING WIDTH

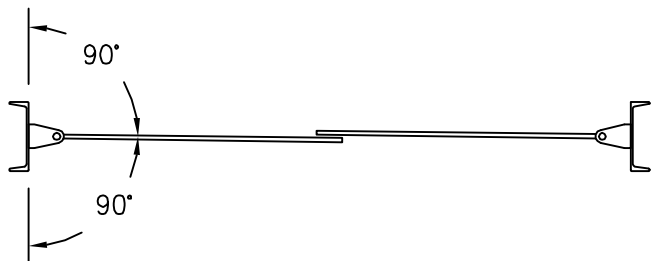

- LEGEND:**
1. GRAVITY ARM ASSEMBLY.
 2. SINGLE-PLY 40 oz. REINFORCED VINYL (T50), DOUBLE-PLY (T100) OR TRIPLE-PLY (T150) - T100 & T150 RECOMMENDED FOR DOOR OPENINGS OVER 8' WIDE x 8' HIGH.
 3. 13 1/2" WIDE x 13" HIGH CLEAR PVC WINDOW.
 4. 1/8" THICK x 48" HIGH BLACK LOW-TEMP HDP

*** RECOMMENDED FRAMING REQUIREMENTS:
 1/8" THICK X 4" WIDE FACE STEEL FRAME MOUNTED TO A SOLID FOUNDATION

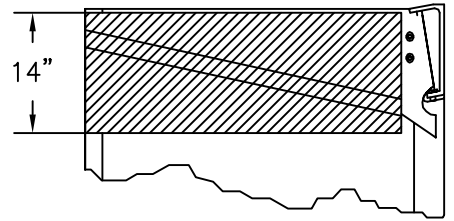

TOP PLATE

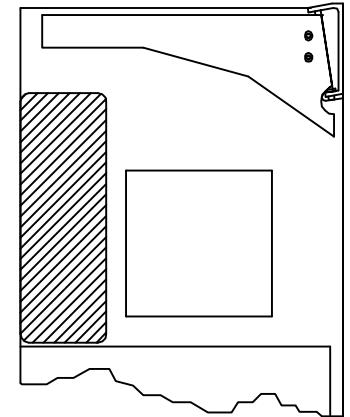

PUSH PLATE

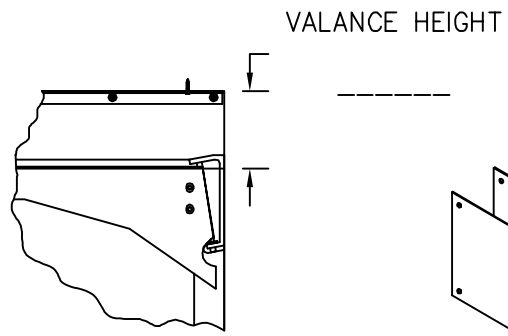

VALANCE

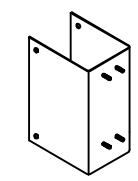

"U" BRACKET

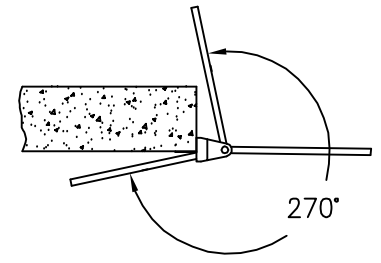

270° HINGE

MODEL

T50 T100 T150

FABRIC COLOR: _____

DOOR OPENING:

_____ W x _____ H

DOUBLE SINGLE

QUANTITY: _____

OPTIONS

(CHECK BOX IF APPLICABLE)

- CUSTOM WINDOW SIZE
 _____ W X _____ H

- STAINLESS STEEL GRAVITY ARM

- HOLD OPEN DEVICE

- WIDE ANGLE 270° HINGE

- TOP PLATE

- MIDDLE PLATE

- TOP & MIDDLE PLATE

- FULL KICKPLATE

- EXTENSION "U" BRACKETS

- VALANCE _____ H

S.S. QUOTE REF. # _____

CUSTOMER _____

APPROVED BY: _____

P/O No.: _____

DATE: _____

SUPER SEAL

SERIES 2000—MODELS T50, T100 & T150
 THERMAL FLEXIBLE VINYL IMPACT DOORS

DATE: NOV-08-18	SCALE: 1:24
DRAWN: OC, AS	DWG NO: L2000-C / 2
APPROVED: RT, ST	PART NO: N/A